

# MILITARY-AEROSPACE APPLICATIONS

*ADVANCED CIRCUIT PROTECTION DEVICES FOR OVERVOLTAGE TRANSIENT EVENTS*



**PROTEK DEVICES®**

ONLY ONE NAME MEANS PROTEK'TION™

According to *National Geographic*\*, there are about 100 lightning bolt strikes on the Earth's surface every single second. Each bolt can contain up to one billion volts of electricity. The *National Severe Storms Laboratory (NSSL)*\* estimates at least 30 million points on the ground are struck on average each year, just in the USA. In the air, perhaps where the military and commercial air fleets are concerned, it is estimated that each airliner in the USA will be hit by lightning once per year. Furthermore, static electricity, which humans very commonly generate, can have some 35,000 volts of electricity. Either a billion volts or 35,000 volts are far more than enough to destroy important electronics within mission-critical systems. In military and aerospace markets, protecting costly equipment – from vehicles to aircraft and beyond – from such electrical events is a requirement.

**TABLE 1 - COMMON MILITARY & AEROSPACE CIRCUIT PROTECTION STANDARDS**

STANDARD	WAVEFORM	VOLTAGE	CURRENT	COMMENTS
MIL-STD-704 (Aircraft)	50ms 50ms 5/20µs	50V 180V 200 - 600V	500A 1800A 12A	Switching Surge Switching Surge Induced Switching
MIL-STD-1275 (Vehicles)	50ms 50ms 0.1ms	100V 40V 250V	200A 2000A -	Surge, 500mΩ Surge, 20mΩ Spike
MIL-STD-1399 (Shipboard)	1.2/50µs 1.2/50µs	2500V 1000V	500A 200A	Spike Spike
MIL-STD-331 (Helicopter)	15/400ns 15ns	25kV 300kV	50A 300kA	Personal Helicopter
DO-160: Section 22 (Lightning Induced Transient Susceptibility) (Airborne Equipment)	1MHz Damped Sine Waveform 3	100V	4A	Level 1
		250V	10A	Level 2
		600V	24A	Level 3
		1500V	60A	Level 4
		3200V	128A	Level 5
	6.9µs/69µs Waveform 4	50V	10A	Level 1
		125V	25A	Level 2
		300V	60A	Level 3
		750V	150A	Level 4
		1600V	320A	Level 5
40µs/120µs Waveform 5A	50V	50A	Level 1	
	125V	125A	Level 2	
	300V	300A	Level 3	
	750V	750A	Level 4	
	1600V	1600A	Level 5	
DO-160: Section 25 (Electrostatic Discharge) (Airborne Equipment)	1/30ns	15kV	56.25A	10 Pulses (Positive & Negative)
MIL-STD-461: Section CS117 (Lightning induced transients, cables & power leads) (Subsystems & Equipment)	Waveform 3 (WF3) 1 MHz and 10 MHz Waveform 4 (WF4) 6.9µs/69µs Waveform 5A (WF5A) 40µs/120µs	1500V 750V 2000V	300A 750A 2000A	External Equipment Levels (Multiple Stroke - First Stroke)
MIL-STD-461: Section CS118 (Personnel Borne ESD) (Subsystems & Equipment)	1/30ns	15kV	30A	5 Pulses (Positive & Negative)

Any computer chip exposed to such electrical transients, without proper electrostatic discharge (ESD) protection, will experience catastrophic destruction. An ESD transient can bore through the layers of a device, severing any trace of an integrated circuit in part or in whole. This can cause intermittent or no operation capabilities for the related system.

**TABLE 2 - DATA TRANSMISSION RATES**

APPLICATION	DATA RATE Mbit/S	CAPACITANCE pF
RS-232	0.20	< 50
CanBus/Device Net	1.0	<30
Ethernet	10	< 20
USB 1.1	12	< 5
RS-485	35	< 3
Fast Ethernet	100	< 1
USB 2.0	480	< 1
GigabitE	1000	< 1
DVI	3960	< 1
USB 3.0	5000	< 1
DisplayPort	5400	< 1
USB 3.1	10000	< 1
HDMI 1.3	10200	< 1
HDMI 2.0	18000	< 1

Because of these concerns, there are extensive military and aerospace standards (as shown in Table 1) defined to protect electronic circuits. MIL-STD-704 defines protection for aircraft, MIL-STD-1275 for vehicles, and MIL-STD-1399 for shipboards. In addition, DO-160 defines added circuit protection for aircrafts and MIL-STD-331 adds helicopters. These standards define how to ensure proper circuit protection against lightning, inductive switching, ESD, electromagnetic interference/radio frequency interference (EMI/RFI), and against nuclear electro-magnetic pulses.

Device capacitance is often a decisive factor in higher data rate applications (see Table 2). A TVS diode, like other semiconductors, has an inherent capacitance. Capacitance is dependent on junction area, doping concentration and the voltage across the diode terminals. The reverse bias voltage is inversely related to device capacitance, as reverse bias increases the device capacitance decreases. As the doping concentration increases, the voltage rating of the diode decreases and device capacitance increases. On the other hand, devices with higher voltage values have smaller junction capacitance. Larger junction area relates to higher current handling capability. But as the device or junction size increases the device capacitance increases along with it.

One of the characteristics of a capacitor is lower impedance to time varying signals. The higher the frequency of a signal, lower the resistance offered to it. So when a TVS diode is used in a high data rate application, the intrinsic device capacitance tends to attenuate the signal. Hence, when the device capacitance is large the attenuation suffered by the high frequency signal is greater.

ProTek Devices has an extensive family of circuit protection components widely used in any of these military and aerospace applications. The components deliver primary and/or secondary side protection against ESD, electrical fast transients (EFT), surge, and lightning. They can also provide common-mode, differential-mode, and low capacitance protection. ProTek Devices' components are well-known for meeting the strictest of standards requirements, from military standards and IEC, to RoHS and REACH, and more. The components are also designed to be provided in small packages suitable for even the smallest footprint military and aerospace applications.

## SELECTION GUIDE



APPLICATION	PREFERRED DEVICES	ALTERNATE DEVICES
Aircraft Power Systems	100KS200CNH, 704 Series, SM30KWE Series	30KPA Series, PHP/PIP Series, PNH704270A/CA
Shipboard Power Systems	100KS200CNH, GPZ1275, SM30KWE Series	30KPA Series, 60KS/90KS Series, PNH1275/B
AC Primary/Secondary	100KS200CNH, PHP/PIP Series, SKC Series	60KS/90KS Series, SMAJ/SMBJ/SMCJ/SMDJ Series, SM10KWE/SM15KWE/SM30KWE Series
AC/DC Power	PSDxxHP Series, SM10KWE/SM15KWE/SM30KWE Series	15/30KPA Series, K Series, SM3KW/SM5KW Series
Antenna	GBLCxx/C Series	GBLCxxI/CI Series
CanBus/Device Net	PAM1CAN	PAM2CAN, PAM3CAN
Control Buttons	PRSB6.8C	PAZC099, PLR0504F
DC-DC Converter	SM10KWE/SM15KWE/SM30KWE Series	15KPA Series, 30KPA Series
DC Power	GPZ1275, GPZ1275B60K, PNH1275/B	PAM5S/PAM6S/PAM8S Series, PPZ516/B
EMP	PRS05, PUSB6B	DLZ Series, PSR05LC
Fast Ethernet	PGBT Series, PTA03-4ULC	SMP6LLC05-2P
Gigabit Ethernet	PGBT Series, PLR2210, PTA03-4ULC	GBLCxx/CI Series, PLR3343, SRV05-4, SRV25-4
HDMI or Display	PLR0514LC, PLRT0504LC, PUSB403	GBLCxxI/CI Series, PLR0502, PLR0508, PLR0524
High Frequency Data Lines	GBLCxx/C Series, PSLCxx/C, SMDAxx/C Series	GBLCxxI/CI Series, PLCDA Series, SM8LC Series
Load Dump	GPZ1275, GPZ1275B60K, PNH1275/B	PAM5S/PAM6S/PAM8S Series, PPZ516/B
Low Frequency Data Lines	PSDxx/C Series, SMDAxx/C Series	PSOTxx/C Series
RS-485	PSM712, SMDB712C	485ELC
USB 3.x	PLR0502-6, PLR0504PLCN, PLRT0504LC, PSD Series, PUSB403	PLR0506LP, PLR0514LC, PLR0521E

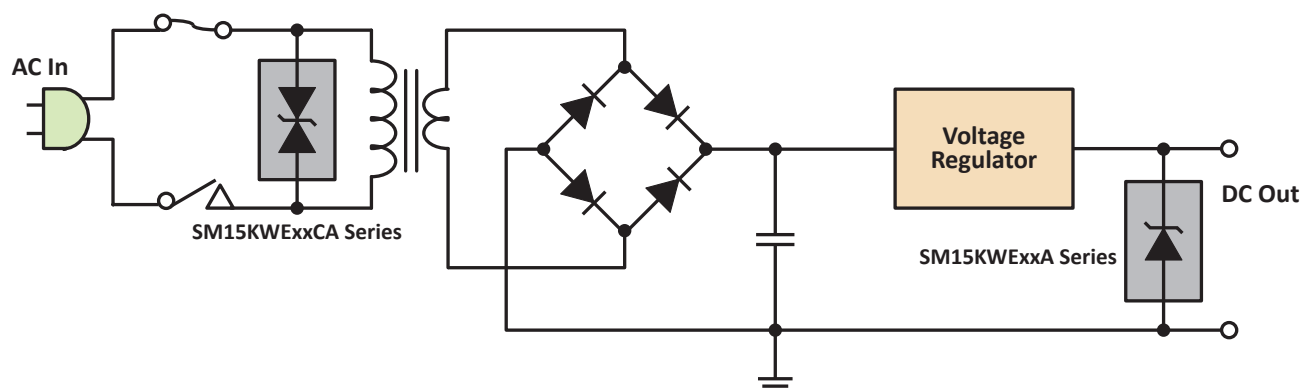

**DO160 Sec. 22 Lightning Protection, AC/DC Power Supply Protection Using the SM15KWExxA/CA Series**

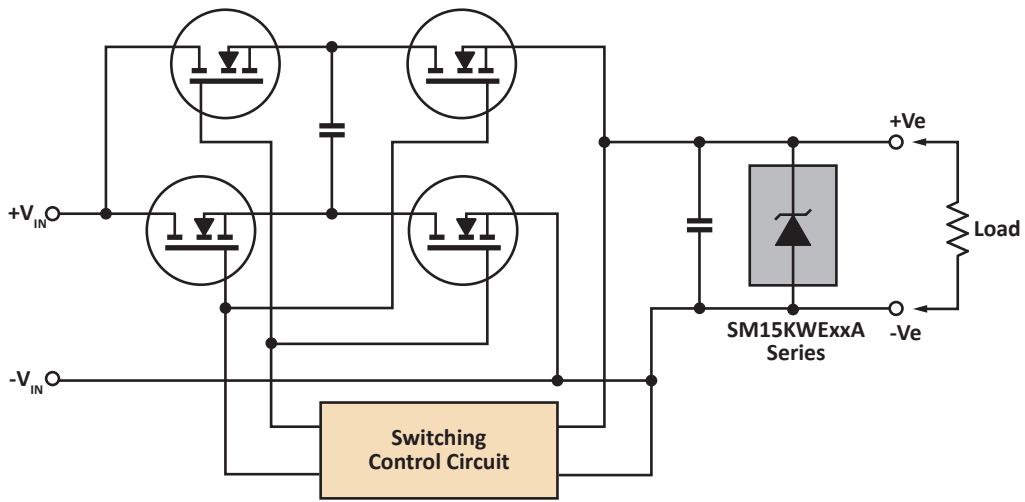

DO160 Sec. 22 Lightning Protection, DC-DC Converter Protection (Charge Pump) Using the SM15KWExxA Series

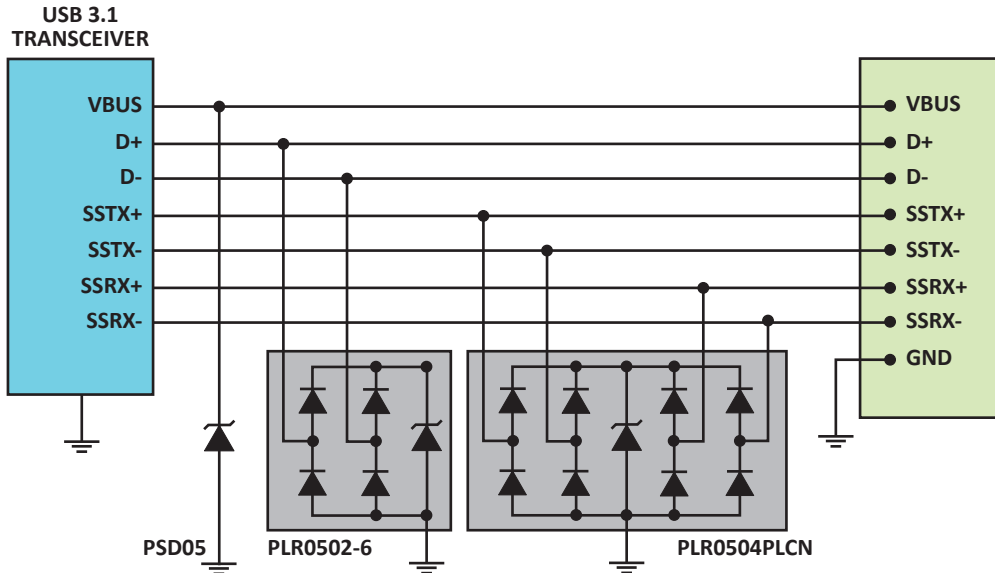

DO160 Sec. 25 ESD Protection, USB 3.1 Interface Protection Using the PLR0502-6, PLR0504PLCN and PSD05

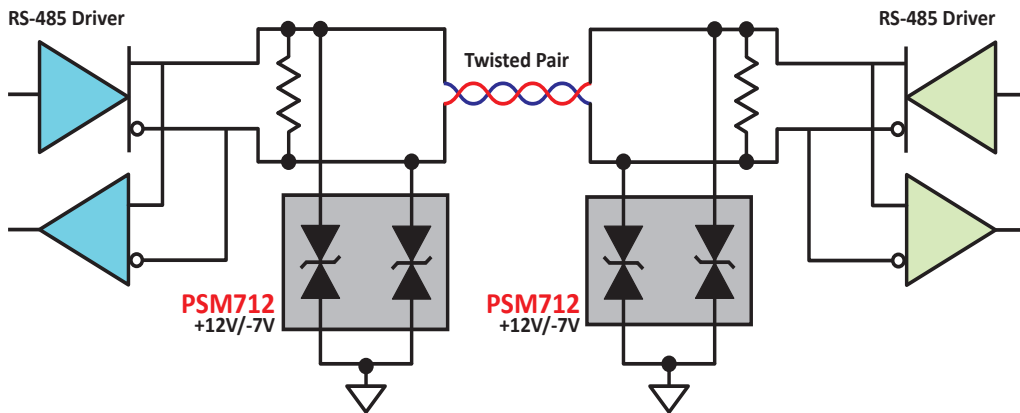

RS-485 Driver Application Using the PSM712



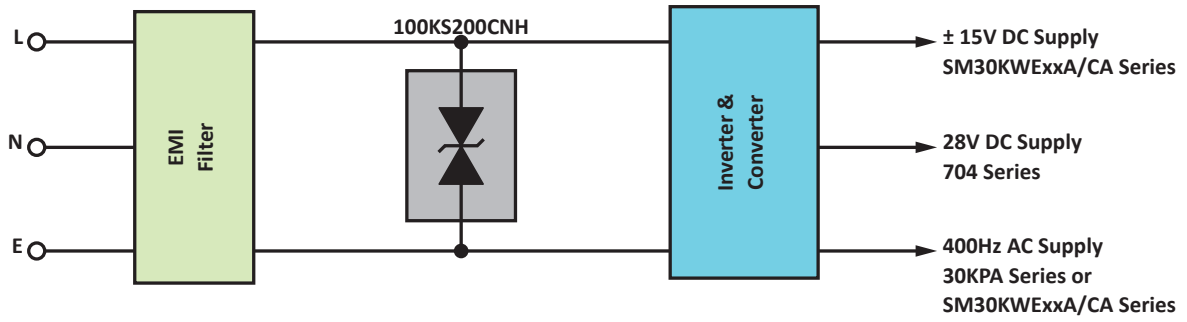

Aircraft Power Supply Protection Using the 100KS200CNH, SM30KWExxA/CA Series, 704 Series and 30KPA Series

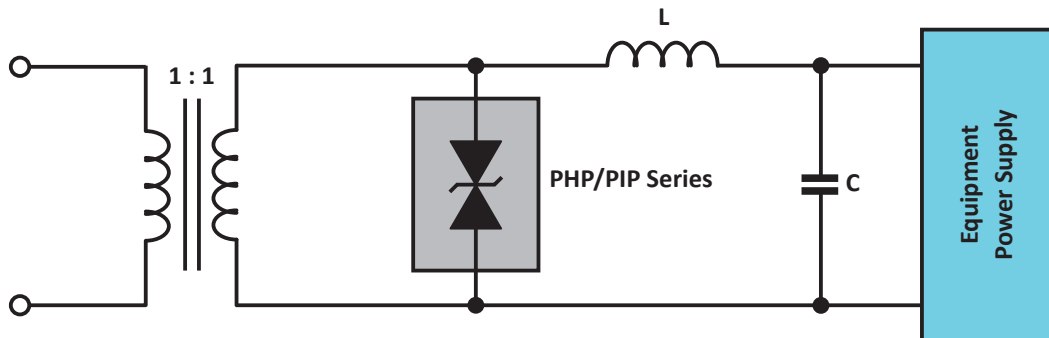

Secondary Side AC Power Protection Using the PHP Series

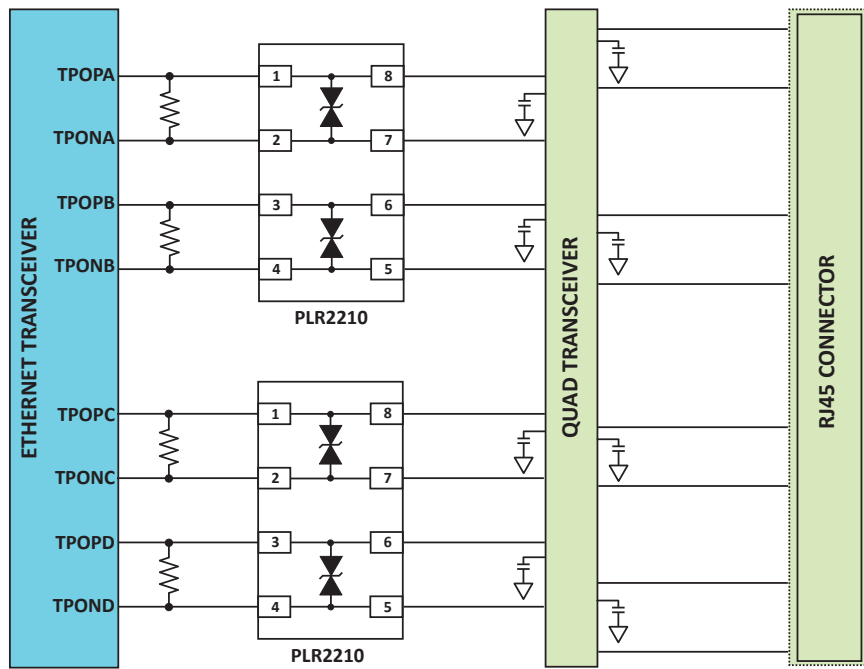

DO160 Sec. 25 ESD Protection, GigabitE Interface Protection Using the PLR2210

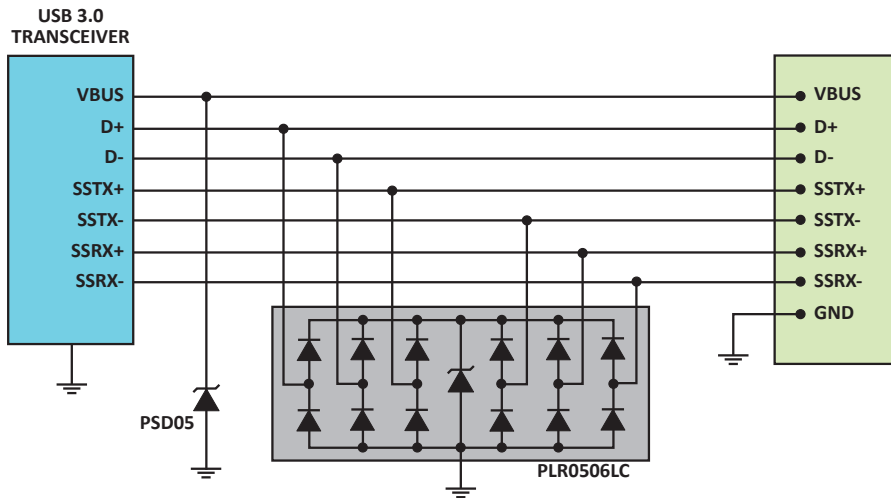

DO160 Sec. 25 ESD Protection, USB 3.0 Interface Protection Using the PLR0506LC with PSD05 for VCC Bus Protection

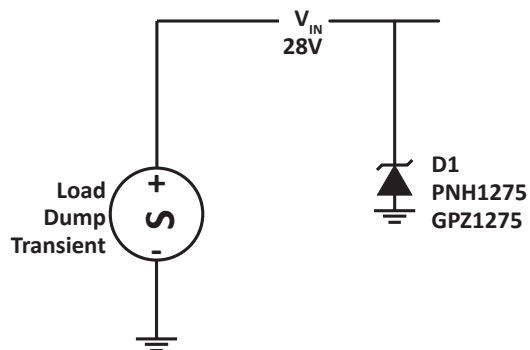

MIL-STD-1275 Land Vehicle Protection Using the PNH1275 or GPZ1275

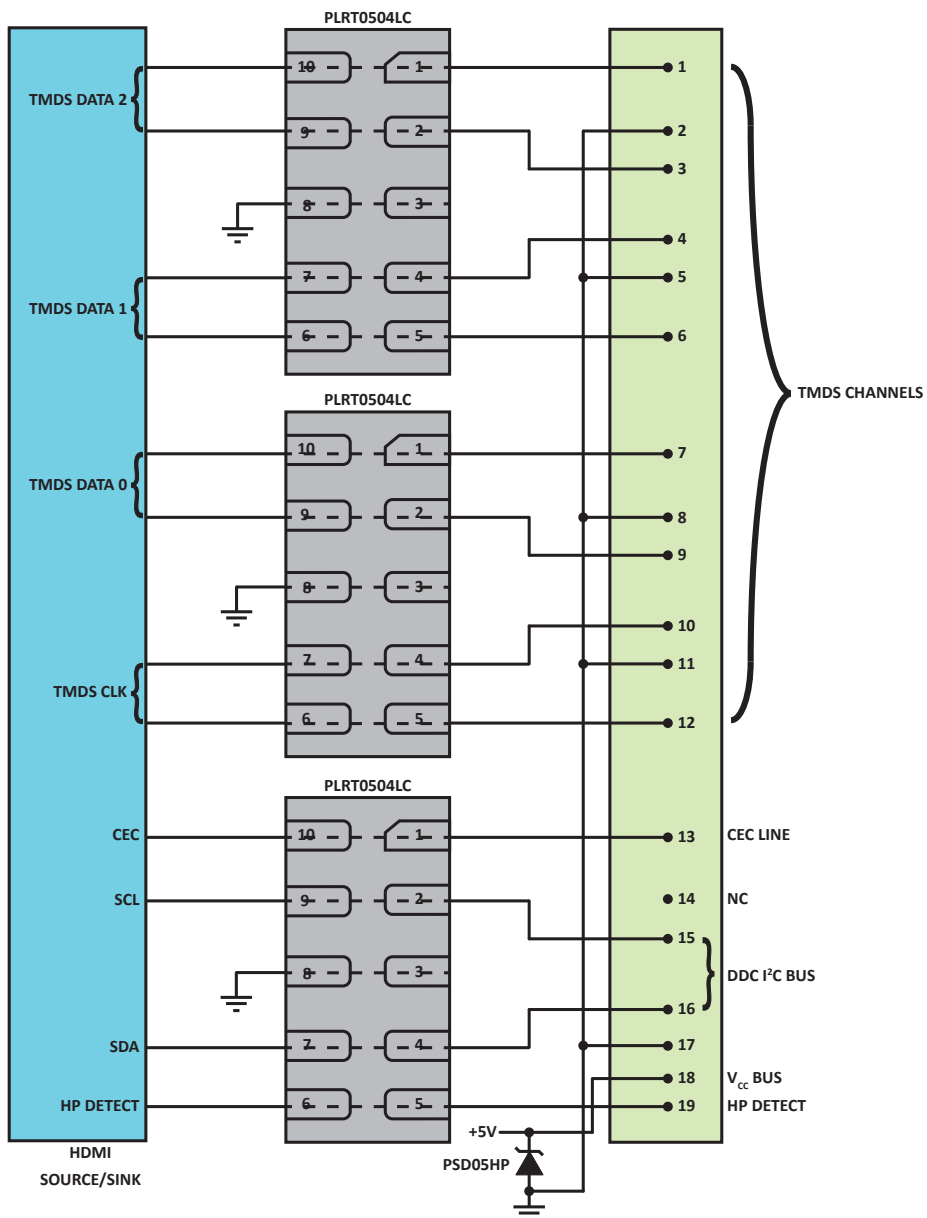

DO160 Sec. 25 ESD Protection, HDMI 2.0 Interface Protection Using the PLRT0504LC and PSD05HP for VCC Bus Protection

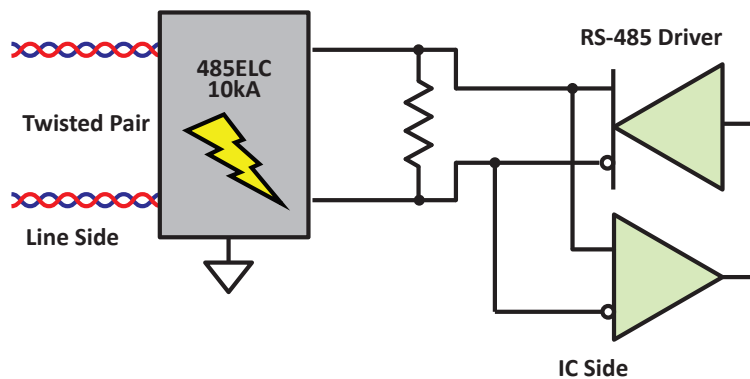

RS-485 Port Protection Using the 485ELC

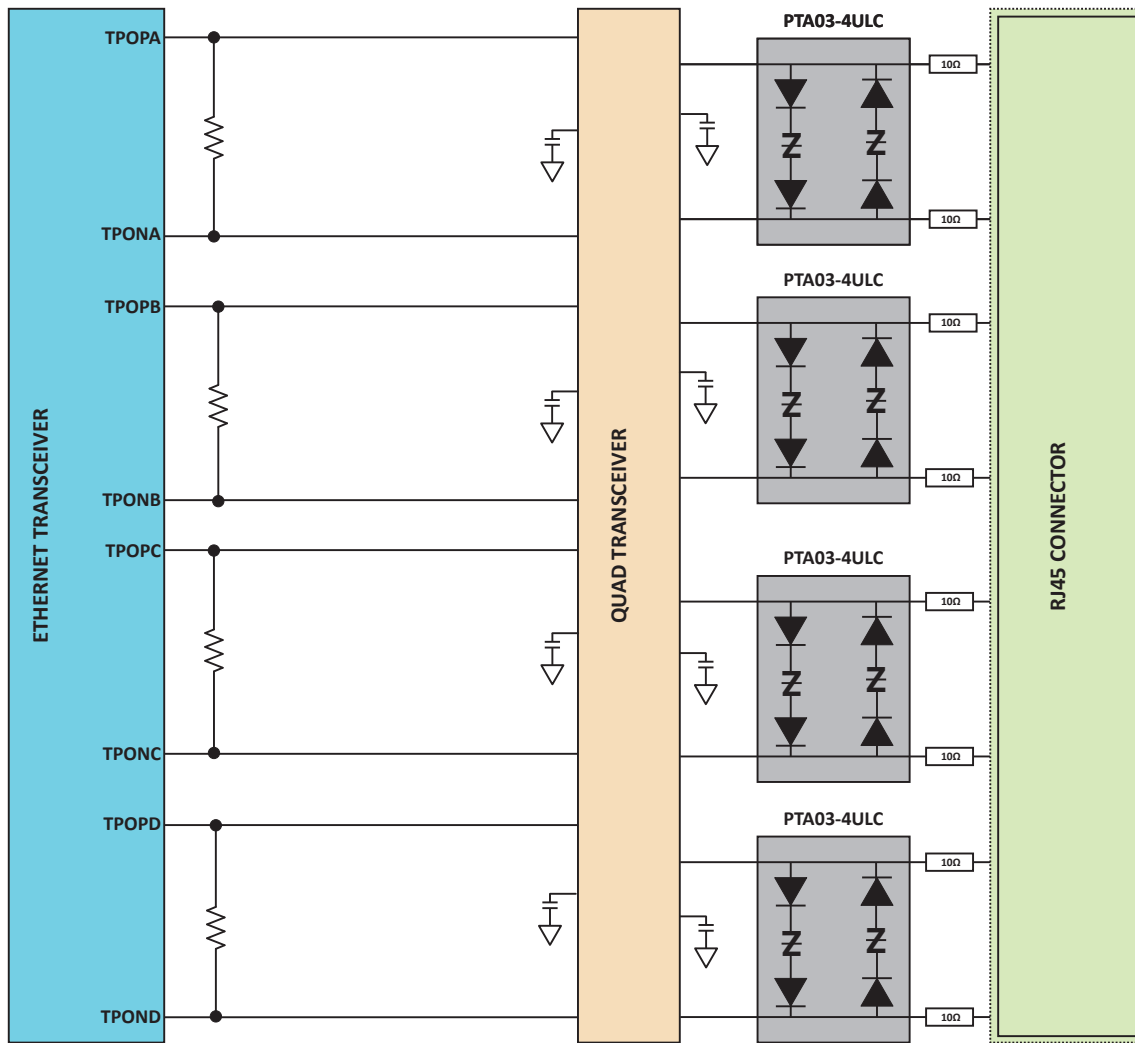

Ethernet 10/100 Protection for DO-160 Section 22 W3L4, W4L4, W5AL2 Using the PTA03-4ULC





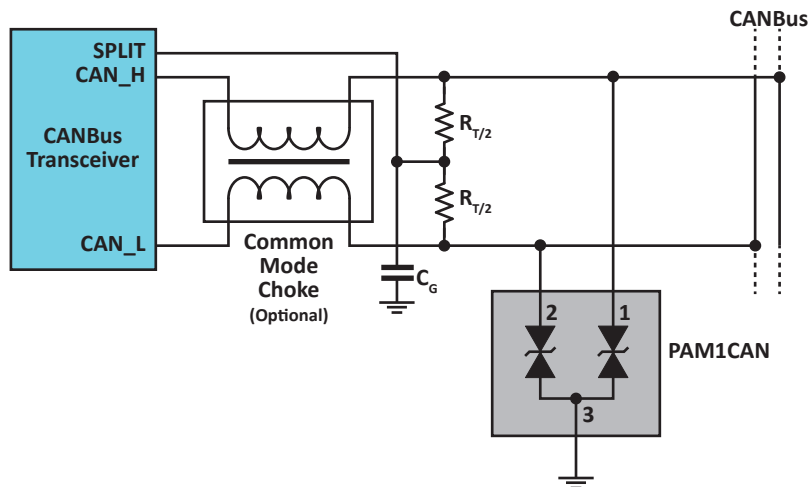

CANBus Protection Using the PAM1CAN

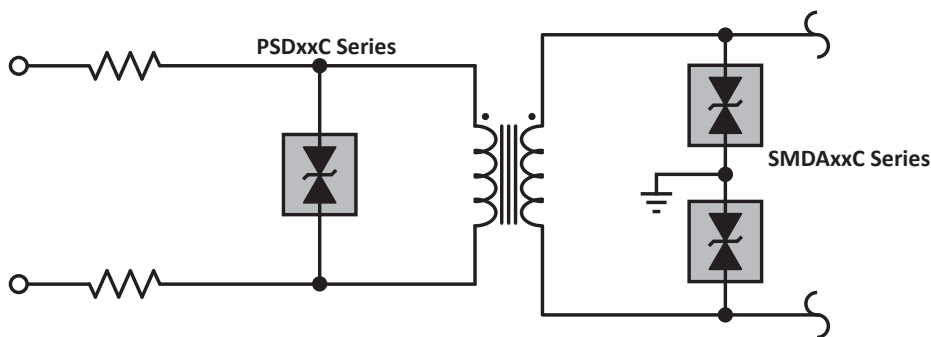

Low Frequency Data Line Protection Using the PSDxxC Series and SMDAxxC Series

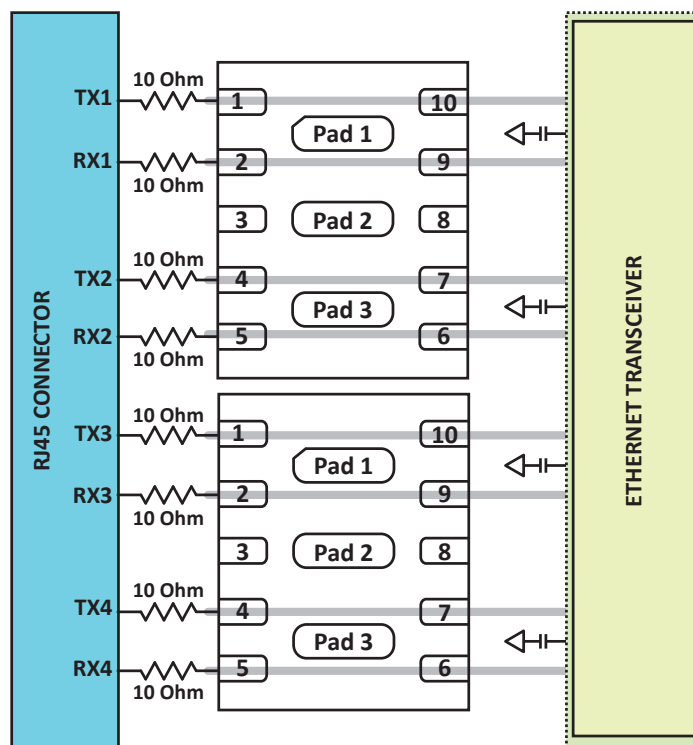

Ethernet 10/100/1000 Protection for DO-160 Section 22 W3L4, W4L4, W5AL2 Using the PGBT2504

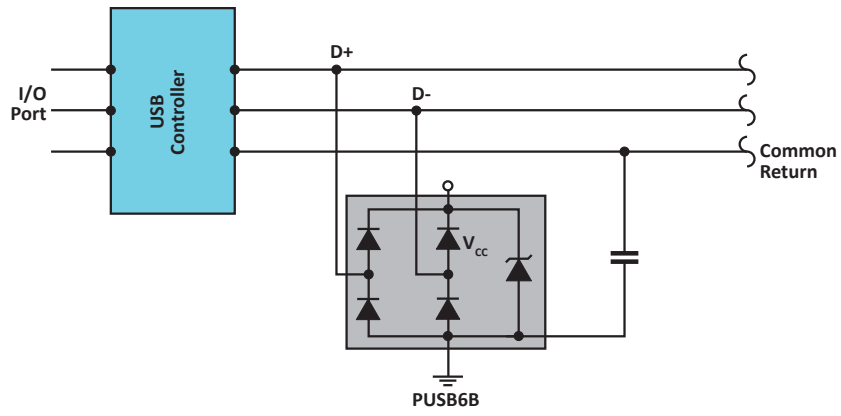

EMP Protection Using the PUSB6.8

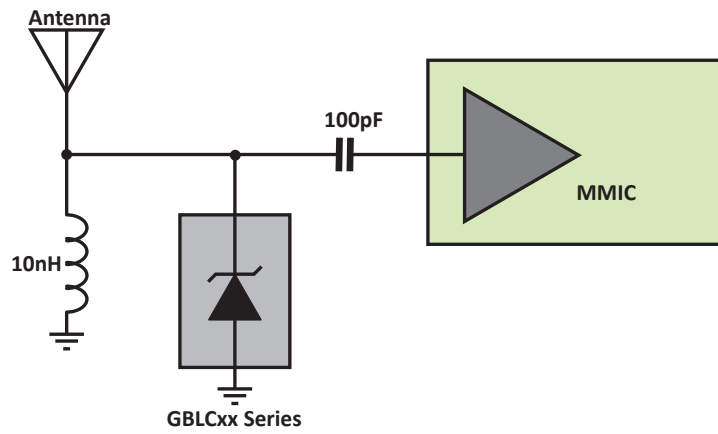

DO160 Sec. 25 ESD Protection, Antenna Protection Solution Using the GBLCx Series



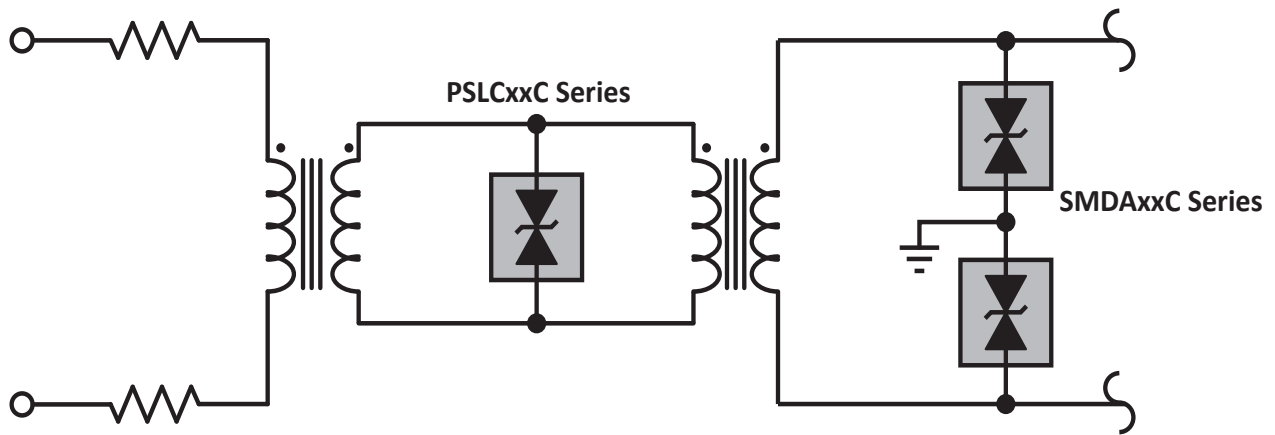

High Frequency Data Line Protection Using the PSLCxxC Series and SMDAxxC Series

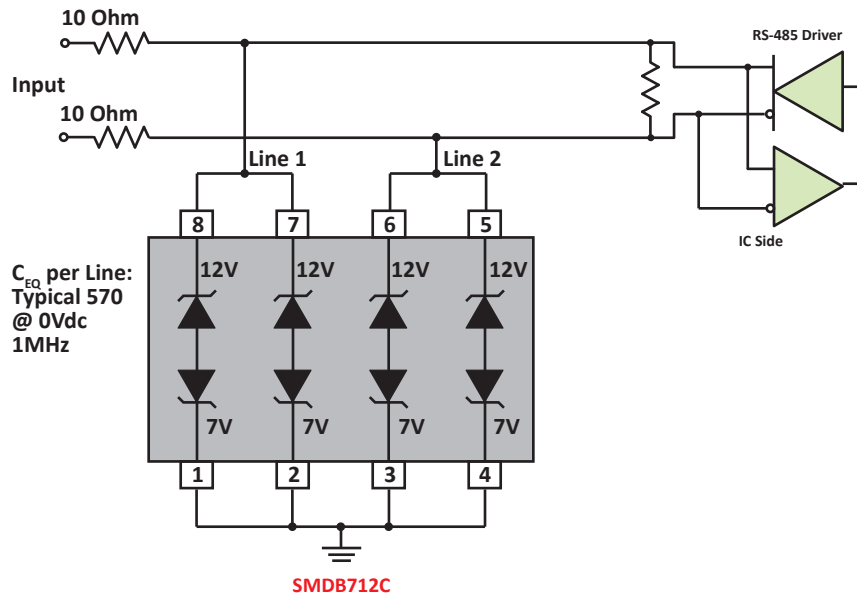

RS485 protection for DO-160 Section 22 W3L4, W4L4, W5AL3 Using the SMDB712C

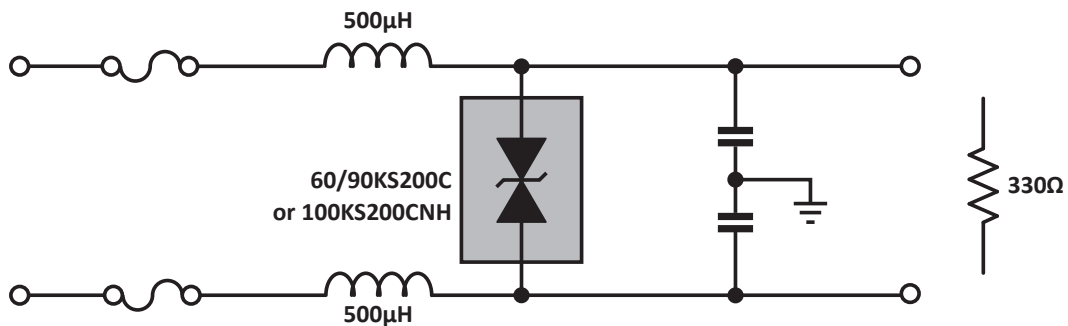

Primary Side AC Power Protection Using the 60/90KS Series or 100KS200CNH

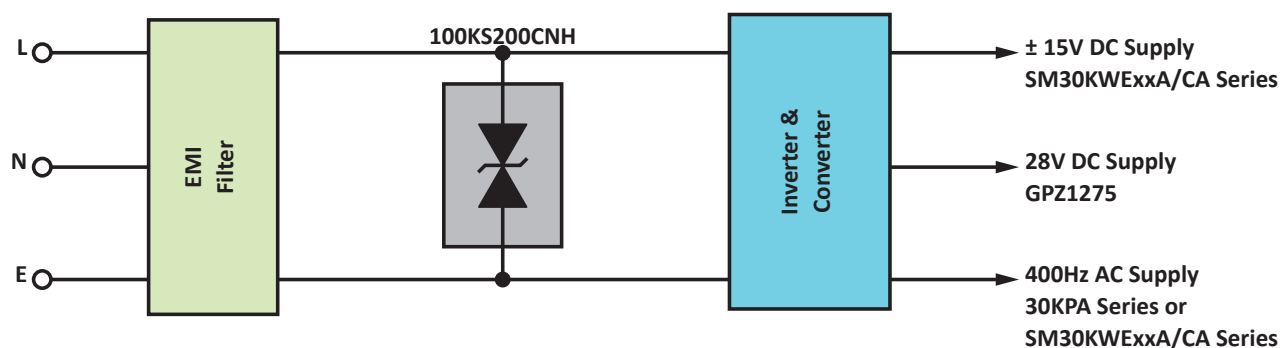

Shipboard Power Supply Protection Using the 100KS200CNH, SM30KWExxA/CA Series, GPZ1275 and 30KPA Series

PART SPECIFICATIONS								
PART NUMBER	STAND-OFF VOLTAGE	BREAKDOWN VOLTAGE	CLAMPING VOLTAGE	PEAK PULSE CURRENT 8/20 $\mu$ s	MAXIMUM LEAKAGE CURRENT	NO. OF LINES	POWER 10/1000 $\mu$ s	PACKAGE
	$V_{WM}$ VOLTS	$V_{(BR)}$ VOLTS	$V_C$ VOLTS	$I_{PP}$ AMPS	$I_D$ $\mu$ A		WATTS	
100KS200CNH	180	200	335	300	0.5	1	100000	Module
15KPA Series	17 - 280	18.9 - 311	32.3 - 452	175 - 33	5000 - 10	1	15000	Axial
30KPA Series	28 - 400	31.2 - 440	50 - 704	606 - 42.6	5000 - 2	1	30000	Axial
485ELC	$\pm 7$	-	20	500	10	1	-	Module
60/90KS Series	180	200	335	180	10 - 0.5	1	60 - 90kW	Module
5.0SMDJ Series	6 - 440	6.67 - 492	10.3 - 713.0	485 - 7	2000 - 1	1	5000	DO-214AB
704 Series	31.5	36	53	300	500 - 100	1	15000	Module
GPZ1275	28	32	55	500	60	1	30000	Module
GPZ1275B60K	28	32	55	1000	60	1	60000	Module
GPZ532	28	32	40	100	50	1	10000	Module
PAM5S Series	14 - 36	15.6 - 40	23.2 - 58.1	115 - 62	10	1	3600	DO-218AB
PAM6S Series	14 - 36	15.6 - 40	23.2 - 58.1	198 - 79	10	1	4600	DO-218AB
PAM8S Series	14 - 48	15.6 - 53.3	23.2 - 85.2	284 - 77.4	10	1	6600	DO-218AB
PHP Series	12 - 708	14 - 835	22 - 1292	341 - 11.6	341 - 11.6	1	7500	Module
PIP Series	12 - 708	14 - 835	22 - 1292	341 - 11.6	341 - 11.6	1	15000	Module
PNH1275/B	28	32	52	865	60	1	45000	Module
PNH704270A/CA	270	287	416.4	95.1	10	1	40000	Module
PPZ516/B	14	16	20	200	40	1	20000	Module
SM3KW Series	8 - 33	8.8 - 36.7	13.6 - 56.3	220 - 53.3	50 - 3	1	3000	DFN-2
SM5KW Series	10 - 36	11.1 - 40.2	17 - 58.1	296 - 86	15 - 8	1	5000	DFN-2
SM10KW Series	10 - 36	11.1 - 40	20 - 72.3	3000 - 829	15 - 8	1	8500	DFN-2
SM10KWE Series	10 - 48	11.1 - 53	17 - 77.4	588 - 129	15 - 8	1	10000	DFN-2
SM15KWE Series	15 - 120	16.9 - 132	24.4 - 193.0	618 - 78	10-5	1	15000	DFN-2
SM30KWE Series	16 - 345	17.8 - 380	26.0 - 560.0	1150 - 53.6	100-5	1	30000	DFN-2
SMAJ Series	5 - 440	6.4 - 492	9.6 - 713	41.7 - 0.6	800 - 1	1	400	DO-214AC
SMBJ Series	5 - 480	6.4 - 537	9.6 - 779	62.5 - 0.77	800 - 1	1	600	DO-214AA
SMCJ Series	5 - 440	6.4 - 492	9.6 - 713	156 - 2.1	800 - 1	1	1500	DO-214AB
SMDJ Series	5 - 440	6.4 - 492	9.6 - 713	313 - 4.2	5000 - 2	1	3000	DO-214AB



## PART SPECIFICATIONS

PART NUMBER	STAND-OFF VOLTAGE $V_{WM}$ VOLTS	BREAKDOWN VOLTAGE $V_{BRI}$ VOLTS	CLAMPING VOLTAGE $V_C$ VOLTS	PEAK PULSE CURRENT 8/20 $\mu$ s $I_{pp}$ AMPS	MAXIMUM LEAKAGE CURRENT $I_D$ $\mu$ A	TYPICAL CAPACITANCE $C$ pF	NO. OF LINES	POWER 8/20 $\mu$ s WATTS	PACKAGE
DLZ Series	5.0 - 30.0	6.0 - 33.3	12.5 - 58.8	10.0	200 - 2	880 - 165	15	1300	CDIP-16
GBLCxxC Series	3.3 - 24.0	4.0 - 26.7	7.0 - 43.0	1.0	5 - 1	3	1	350	SOD-323
GBLCxxCI Series	3.0 - 24.0	4.0 - 26.7	7.0 - 43.0	1.0	5 - 1	0.6	1	250	SOD-323
PAM1CAN	24.0	25.4	46.0	3.0	0.002	11	2	200	SOT-23
PAM2CAN	24.0	25.4	60.0	4.0	0.05	11	2	230	SOT-23
PAM3CAN	24.0	25.4	70.0	2.1	0.002	5	2	150	SOT-23
PAZC099	5.0	6.0	12.0	1.0	0.5	0.5	4	100	SOT-23-6
PGBT Series	2.5 - 3.3	3.0 - 5.0	6.0	5.0	0.1	1.0	2 Pairs	500	DFN-10
PLCDA Series	3.3 - 24	4.5 - 26.7	7.0 - 43.0	1.0	125 - 1	5	2	500	SO-8
PLR0502	5.0	6.0	20.0	10.0	1	0.6	2	200	SOT-543
PLR0502-6	5.0	6.0	17.0	3.0	1	0.7	2	50	SC-89
PLR0504F	5.0	6.0	25.0	5.0	3	1.9	4	200	SC70-6L
PLR0504PLCN	5.0	6.0	8.0	1.0	0.5	1.5	4	250	DFN-10
PLR0506LP	5.0	6.0	18.0	4.0	3	0.8	6	72	DFN-8
PLR0508	5.0	6.0	13.0	5.0	1	1.6	8	200	DFN-10
PLR0514LC	5.0	6.0	12.0	1.0	1	0.35	4	-	DFN-10
PLR0521E	5.0	6.0	20.0	4.0	1	0.4	1	80	DFN-2
PLR0524	5.0	6.0	12.0	1.0	0.5	0.7	4	150	DFN-10
PLR2210	2.5	2.7	6.0	2.0	0.05	0.6	2	170	DFN-8
PLR3343	3.3	5.6	10.0	1.0	1	0.25	4	150	DFN-10
PLRT0504LC	5.0	6.2	5.0	7.0	0.05	0.3	4	35	DFN-10
PRSB6.8C	4.7	5.7	13.0	1.0	0.5	15	1	50	DFN-2
PSDxx	3.3 - 36.0	4.0 - 40.0	6.5 - 60.0	1.0	125 - 1	500 - 35	1	500	SOD-323
PSDxxHP	5.0 - 12.0	6.0 - 13.3	9.8 - 19.1	1.0	20 - 2	800 - 440	1	1000	SOD-323
PSLCxxC	3.3 - 24.0	4.0 26.7	19.0 - 56.0	20.0 - 6.0	125 - 1	3	1	350	SOT-143
PSM712	7.0, 12.0	7.5, 13.3	11.0, 19.0	1.0	20, 1	75	1	600	SOT-23
PSOTxxC	3.3 - 36.0	4.0 - 40.0	6.5 - 51.0	1.0	125 - 1	500 - 60	1	500	SOT-23
PSR05	5.0	6.0	20.0	28.0	5	10	2	500	SOT-143
PSR05LC	5.0	6.0	20.0	28.0	5	2.5	2	500	SOT-143
PTA03-4ULC	3.3	2.2	29.0	70.0	0.1	2.4	4	2000	SO-8
PUSB403	3.3	4.5	4.0	1.0	0.1	0.45	4	-	DFN-10
PUSB6B	5.25	6.0	13.2	35.0	10	15	2	500	SO-8
SKC Series	58.0 - 86.0	64.0 - 95.0	110 - 157	10kA	5	-	1	1600	SMT0-218
SM8LC Series	5.0 - 24.0	6.0 - 26.7	24.6 - 48.5	45.0 - 22.0	100 - 4	25	2	800	SO-8
SMDAxx/C Series	3.3 - 36.0	4.0 - 40.0	6.5 - 51.0	1.0	125 - 1	800 - 45	4	500	SO-8
SMDB712C	7.0 - 12.0	8.5 - 13.3	13.4 - 19.0	1.0	10 - 2	284	4	800 - 1600	SO-8
SMP6LLCxx-2P	5.0 - 15.0	6.0 - 16.7	26.0 - 50.0	150.0-110.0	300 - 2	5	2	3900	SO-16
SRV05-4	5.0	6.0	15.0	5.0	5	2.5	4	500	SOT-23-6
SRV25-4	2.5	3.0	7.4	10.0	0.5	1.7	4	800	DFN-10

## COMPANY PROFILE

In business more than 30 years, ProTek Devices™ is a privately held semiconductor company. The company offers a product line of overvoltage protection that include Transient Voltage Suppressor (TVS) Arrays, Steering Diode Array Hybrids, High-power Components and Modules, as well as Steering Diodes, EMI Filter/TVS Arrays and Thyristor Surge Suppressors. These components deliver circuit protection in electronic systems from numerous overvoltage events. They include lightning; electrostatic discharge (ESD); nuclear electromagnetic pulses (NEMP); inductive switching; and electromagnetic interference (EMI) / radio frequency interference (RFI). ProTek Devices is an ISO 9001 certified company.

## CONTACT US

### Corporate Headquarters

2929 South Fair Lane  
Tempe, Arizona 85282  
USA

### By Telephone

General: 602-431-8101  
Sales: & Marketing: 602-414-5109  
Customer Service: 602-414-5114  
Product Technical Support: 602-414-5107

### By Fax

General: 602-431-2288

### By E-mail:

Asia Sales: [asiasales@protekdevices.com](mailto:asiasales@protekdevices.com)  
Europe Sales: [europesales@protekdevices.com](mailto:europesales@protekdevices.com)  
U.S. Sales: [ussales@protekdevices.com](mailto:ussales@protekdevices.com)  
Distributor Sales: [distysales@protekdevices.com](mailto:distysales@protekdevices.com)  
Customer Service: [service@protekdevices.com](mailto:service@protekdevices.com)  
Technical Support: [support@protekdevices.com](mailto:support@protekdevices.com)

### Web

[www.protekdevices.com](http://www.protekdevices.com)

## ROHS & REACH COMPLIANCE

All devices, with the exception the modules/axial leads are Lead-Free, RoHS & REACH compliant. These products are designated as "lead free" and meet the requirements of the European Union's restriction on the use of hazardous substances in electrical equipment as stated in (RoHS) direction, 2002/95/EC. ProTek Devices defines "lead free" as products that are compatible with current RoHS requirements for the 6 "banned" substances: Lead (Pb, <1000ppm), Cadmium (Cd, <100ppm), Mercury (Hg, <1000ppm), Hexavalent Chromium (Cr6+, <1000ppm), Poly Brominated Biphenyls (PBB, <1000ppm), Poly Brominated Diphenyl Ethers (PBDE, <1000ppm). This includes the requirements that lead not exceed 0.1% by weight in homogeneous materials.

COPYRIGHT © ProTek Devices (2024) - This literature is subject to all applicable copyright laws and is not for resale in any manner.

SPECIFICATIONS: ProTek Devices reserves the right to change the electrical and or mechanical characteristics described herein without notice.

DESIGN CHANGES: ProTek Devices reserves the right to discontinue product lines without notice and that the final judgment concerning selection and specifications is the buyer's and that in furnishing engineering and technical assistance. ProTek Devices assumes no responsibility with respect to the selection or specifications of such products. ProTek Devices makes no warranty, representation or guarantee regarding the suitability of its products for any particular purpose, nor does ProTek Devices assume any liability arising out of the application or use of any product or circuit and specifically disclaims any and all liability without limitation special, consequential or incidental damages.

LIFE SUPPORT POLICY: ProTek Devices products are not authorized for use in life support systems without written consent from the factory.